



# DECA VIBRATOR

Division of DECA Products, Inc.

## PNEUMATIC LINEAR VIBRATORS WITH INTERNAL PISTON

*Model DLV Series*



*Vibration Technology*

# DLV Series Linear Vibrators

Deca's DLV Series Pneumatic Linear Vibrators with Internal Piston are particularly suitable for conveying, compacting and dislodging of bulk solids due to precise linear vibrations. They reach optimum results for emptying bins or as drives for vibrating conveyors or feeders.

## Technical Data

Model	2 BAR = 30 PSI								4 BAR = 58 PSI								6 BAR = 87 PSI							
	Vibration		Force		Working Moment		Air Consumption		Vibration		Force		Working Moment		Air Consumption		Vibration		Force		Working Moment		Air Consumption	
	VPM	kg	lb	kgcm	in lb	l/min	cfm	VPM	kg	lb	kgcm	in lb	l/min	cfm	VPM	kg	lb	kgcm	in lb	l/min	cfm			
DLV-15	4500	2.8	6.2	0.02	0.02	9	0.3	5625	5.9	13.0	0.03	0.03	15	0.5	6672	8.3	18.3	0.03	0.03	21	0.7			
DLV-22	2850	9.0	19.8	0.20	0.17	32	1.1	3450	14.2	31.3	0.21	0.18	50	1.8	4050	19.6	43.2	0.21	0.18	73	2.6			
DLV-30	2475	14.8	32.6	43	37.20	45	1.6	3075	24.3	53.6	0.46	0.40	90	3.2	3450	30.6	67.5	0.46	0.40	140	4.9			
DLV-45	1800	38.6	85.1	1.07	0.93	56	2.0	2250	68	149.9	2.4	2.08	125	4.4	2625	92	202.8	2.4	2.08	194	6.8			
DLV-60	1200	62.0	136.7	7.67	6.64	48	1.7	1500	110	242.5	8.76	7.58	125	4.4	1700	141	310.8	8.76	7.58	202	7.1			

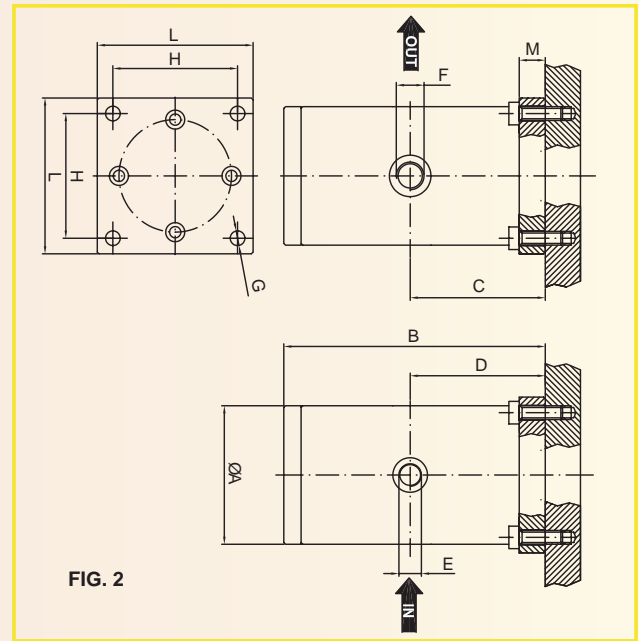
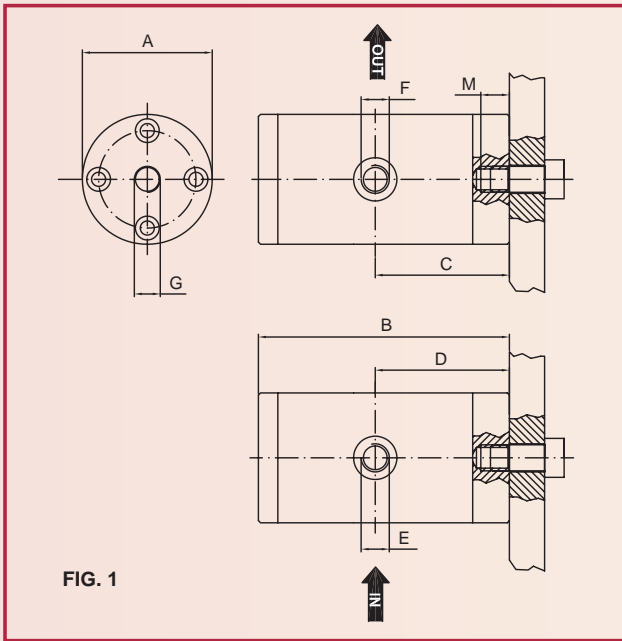

For activation a 3/2 way electrovalve and filtered compressed air are required.

## Overall Dimensions

Model	FIG.	A		B		C		D		E	F	G	H		Weight		L		M	
		mm	in	mm	in	mm	in	mm	in				mm	in	kg	lb	mm	in	mm	in
DLV-15	1	32	1.26	69	2.72	37	1.46	37	1.46	M5	1/8"	M8	/	/	0.17	0.37	/	/	9	0.35
DLV-22	1	45	1.77	105	4.13	56	2.2	56	2.2	1/8"	1/8"	M10	/	/	0.50	1.10	/	/	13	0.51
DLV-30	1	60	2.36	116	4.57	62	2.44	62	2.44	1/4"	1/4"	M12	/	/	1.03	2.27	/	/	13	0.51
DLV-45	2	80	3.15	151	5.94	78	3.07	78	3.07	1/4"	3/8"	ø 8.5	72	2.83	2.86	6.30	90	3.54	15	0.59
DLV-60	2	115	4.53	224	8.82	115	4.53	115	4.53	1/2"	1/2"	ø 13	102	4.02	4.60	10.14	130	5.12	20	0.79

## Features & Benefits

- Standard temperature application: from -10° C (14° F) to 150° C (300° F)
- Explosion-proof and maintenance-free • Adjustable frequency and amplitude
  - Wide oscillations • Excellent start/stop characteristics
- Starts in any position • Minimum sound emission • Low air consumption



**DECA**  
**VIBRATOR**  
Division of DECA Products, Inc.

6/07

P.O. Box 1286 • Bridgeview, Illinois 60455-0286  
(708) 974-9422 • Fax (708) 974-9429  
1-866-384-3788

Website: [www.decavibrator.com](http://www.decavibrator.com) • Email: [sales@decavibrator.com](mailto:sales@decavibrator.com)  
SPECIFICATIONS SUBJECT TO CHANGE