



# DECA VIBRATOR

Division of DECA Products, Inc.

## *PNEUMATIC EXTERNAL HIGH FREQUENCY ROLLER VIBRATORS*

*Models CR and DR*



Model DR



Model CR



*Vibration Technology*

# PNEUMATIC EXTERNAL HIGH FREQUENCY ROLLER VIBRATORS

## Description

Deca's CR & DR Series Pneumatic External High Frequency Roller Vibrators impart high frequencies with high centrifugal forces at large amplitudes needed for the consolidation and compaction of Precast & Prestressed Concrete. These vibrators generate pressure waves that separate aggregate particles and reduce friction between them. This action releases entrapped air and therefore increases density. They are also ideal for Refractory compaction and as a Flow-aid device for Railcar unloading and the evacuation of dry bulk material in all types of bins and hoppers.

There is very little maintenance required due to its simple but rugged design - a single or dual steel roller rotating around a hardened steel shaft with one vane. These units have an operating range of 30 to 90 psi and require a Filter-Regulator-Lubricator.



## TECHNICAL DATA

Model	2 BAR - 29 PSI					4 BAR - 58 PSI					6 BAR - 87 PSI				
	Vibration	Force		Air consump.		Vibration	Force		Air consump.		Vibration	Force		Air consump.	
		V/min	Kg	Lb	L/min		Cfm	V/min	Kg	Lb		L/min	Cfm	V/min	Kg
CR-700	8,550	169	372	963	34.0	14,250	354	780	1586	56.0	19,000	544	1200	1812	64.0
CR-1600	8,100	281	620	1048	37.0	13,500	590	1300	1642	58.0	18,000	907	2000	1869	66.0
CR-4400	7,200	454	1000	1104	39.0	1,200	953	2100	1699	60.0	16,000	1452	3200	1926	68.0
CR-5500	4,000	544	1200	991	35.0	7,000	1134	2500	1472	52.0	9,000	2495	5500	934	33.0
CR-6500	3,000	680	1500	906	32.0	5,000	1588	3500	1388	49.0	7,500	2948	6500	1076	38.0
CR-7800	2,000	454	1000	878	31.0	3,000	1588	3500	1303	46.0	5,000	3538	7800	1133	40.0
DR-700	8,550	169	372	963	34.0	14,250	354	780	1586	56.0	19,000	544	1200	1812	64.0
DR-1600	8,100	281	620	1048	37.0	13,500	590	1300	1642	58.0	18,000	907	2000	1869	66.0
DR-4400	7,200	454	1000	1104	39.0	12,000	953	2100	1699	60.0	16,000	1452	3200	1926	68.0
DR-5500	4,000	544	1200	991	35.0	7,000	1134	2500	1529	54.0	9,000	2495	5500	1671	59.0
DR-6500	3,000	680	1500	906	32.0	5,000	1588	3500	1388	49.0	7,500	2948	6500	1614	57.0
DR-7800	2,000	454	1000	878	31.0	3,000	1588	3500	1303	46.0	5,000	3538	7800	1444	51.0

## Features & Benefits

- High Force & Frequency • Low Maintenance/Long Life
- Portable (CR Series) or Permanent (DR Series) Mounting Systems • Light Weight
- Heavy Duty Design (Hardened Steel Shaft, Rollers, & End Plates) • Low Cost

## Applications

- Precast Forms • Vibration Table • Concrete Columns • Concrete Pipe
- Ornamental Concrete • Railcar Unloading • Bunkers and Silos • Tunnels
- Vibrating Screeds • Manholes & Culverts



# DECA VIBRATOR

Division of DECA Products, Inc.

# PNEUMATIC EXTERNAL HIGH FREQUENCY ROLLER VIBRATORS

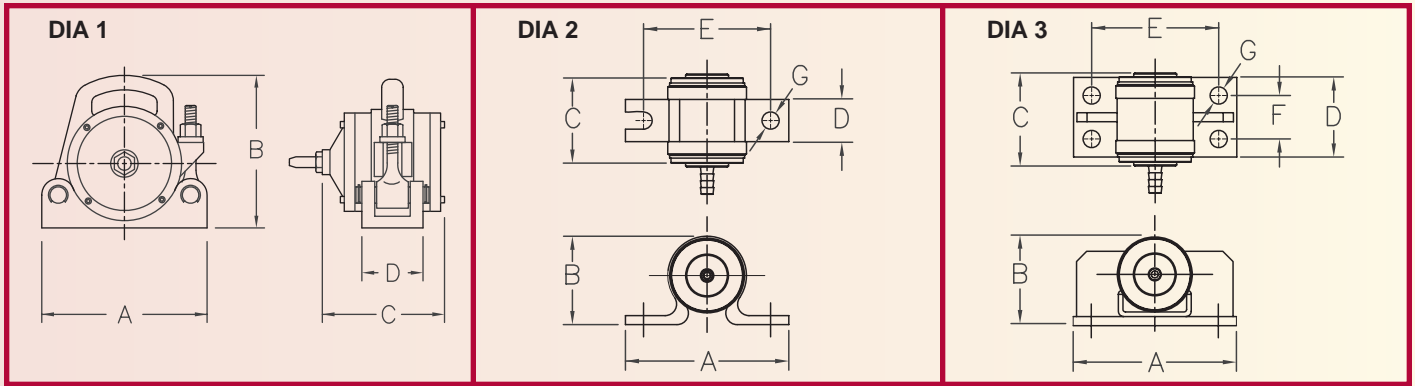

## Air Fitting for all Vibrators

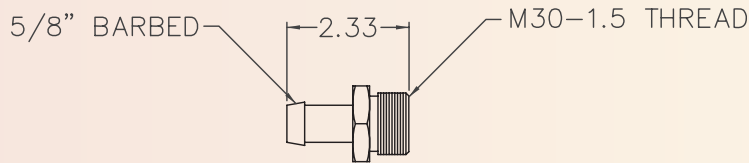

## OVERALL DIMENSION

Model	Diag.	A		B		C		D		E		F		G		Weight	
		mm	in	mm	in	mm	in	mm	in	mm	in	mm	in	mm	in	Kg	lb
CR-700	1	178	7.00	140	5.50	171	6.75	93	3.67	N/A		N/A		N/A		6.80	15.00
CR-1600																7.26	16.00
CR-4400																7.71	17.00
CR-5500	1	235	9.25	229	9.00	178	7.00	92	3.62	N/A		N/A		N/A		14.97	33.00
CR-6500																17.24	38.00
CR-7800																18.14	40.00
DR-700	2	220	8.66	110	4.33	175	6.89	60	2.36	178	7.00	N/A		18	0.71	8.16	18.00
DR-1600																8.62	19.00
DR-4400																9.98	22.00
DR-5500	3	260	10.23	190	7.48	165	6.50	140	5.51	200	7.87	70	2.75	17	0.67	16.78	37.00
DR-6500																18.14	40.00
DR-7800																20.41	45.00

## Spare Parts

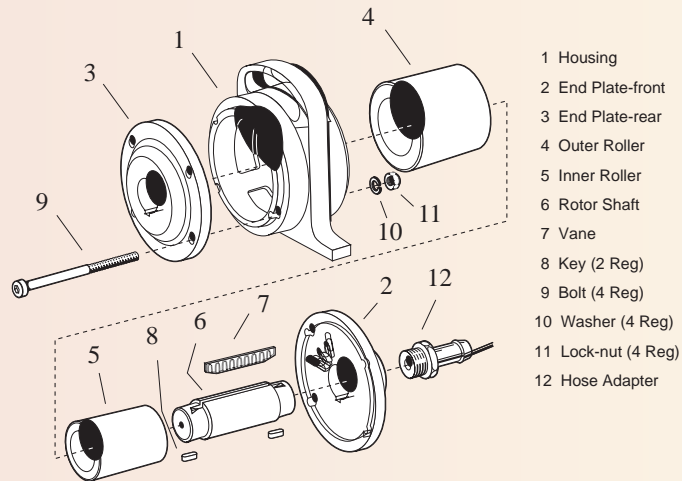

**DECA**  
**VIBRATOR**  
Division of DECA Products, Inc.

P.O. Box 1286 • Bridgeview, Illinois 60455-0286

(708) 974-9422 • Fax (708) 974-9429

1-866-384-3788

Website: [www.decavibrator.com](http://www.decavibrator.com) • Email: [sales@decavibrator.com](mailto:sales@decavibrator.com)

SPECIFICATIONS SUBJECT TO CHANGE