

# HIGH FREQUENCY ELECTRIC VIBRATORS



## BALL VIBRATORS

Compact, lightweight, can be used virtually anywhere



## TRUCK VIBRATORS

Dump wet, sticky, and frozen material  
12 and 24 volt; "The Original"



## ELECTRIC VIBRATORS

The highest quality Electric  
Vibrator you can buy



## HYDRAULIC VIBRATORS

Powerful-Quiet-Efficient  
Adjustable weights and frequency



## AIR VIBRATORS

Hardworking-Tough-Dependable  
Permanent or quick change base



# DECA VIBRATOR

Division of DECA Products, Inc.

# HIGH FREQUENCY ELECTRIC VIBRATORS



## HIGH FREQUENCY VIBRATORS

With more than 30 years of experience in the vibrator equipment industry, Deca Industries provides high performance, cost effective solutions to material flow problems. Deca's line of high quality High Frequency Vibrators are compact and lightweight, and can be mounted where material settling or levelling problems occur.

## DECA IS QUALITY

From design through manufacturing, Deca High Frequency vibrators produce more force for the size, weight and cost than any other type of vibrator available.

These vibrators also offer durability and ruggedness. Deca High Frequency Vibrators effectively operate in extreme environments.

## ADD QUALITY TO YOUR PRODUCT

When used on a concrete form, mold or table, quality shows. High Frequency Vibrators force air out and material down, resulting in a stronger, smoother and more dense product. High Frequency Vibrators used on vibrating tables can save time and money, add more product to bulk containers. Deca's line of High Frequency Vibrators can be easily installed and more quickly integrated into automated systems.

## OUR BUSINESS IS VIBRATORS

Ideal for a variety of industries, applications and materials. Deca Industries offers its products through a strong network of dealers and distributors. Providing expert technical assistance, an engineering department for special applications, and fast repair service, Deca Industries understands your vibrator needs.

For more information and a list of Deca Industries dealers, please call (708) 974-9422.



Division of DECA Products, Inc.

P.O. Box 1286 • Bridgeview, Illinois 60455-0286

(708) 974-9422 • Fax (708) 974-9429

Website: [www.decavibrator.com](http://www.decavibrator.com) • Email: [sales@decavibrator.com](mailto:sales@decavibrator.com)

SPECIFICATIONS SUBJECT TO CHANGE

COPYRIGHT ©2005 DECA PRODUCTS, INC.

## FEATURES



**U1- 1600**  
Totally "O" Ring  
Sealed from  
dirt & water

**U1- 1600**  
Wedge Mount



**VIBRATING  
TABLE**

## HIGH FREQUENCY ELECTRIC VIBRATORS

### PERFORMANCE

MODEL *	VOLTAGE <sup>1,2,3,4</sup>	AMPS	MAX.RPM	HP	Force lb. (in lbs.)			dB <sup>5</sup>
					1	2*	3	
U1-75	115	.7	9000	1/15	75 (.03)			50
U1-500	115	3.7	9000	1/4	150 (.07)	350 (.15)	500 (.22)	50
U1-500	230	1.9	9000	1/4	150 (.07)	350 (.15)	500 (.22)	50
U1-1600	115	15.	9000	1/3	930 (.45)	1330 (.58)	1799(.78)	58
U1-1600	230	7.5	9000	1/3	930 (.45)	1330 (.58)	1799(.78)	58

- Standard Setting
- 1) Motors are universal brush type
- 2) Motor enclosure: U1-75, open fan cooled. U1-500, and U1-1600, totally enclosed non-ventilated
- 3) Cord lengths: U1-75, 8ft. to plug. U1-500 & U1-1600, 7ft. to motor starter 1ft. to plug.
- 4) All units are AC/DC, 1PH, 60hz
- 5) Sound produced in decibels - decibel reading taken with the vibrator mounted on a 400 lb. plate at a distance of 3ft. from dB meter - A scale - slow response.
  - \* A) U1-75, Continuous duty.
  - B) U1-500 & U1-1600 are intermittent duty - rule of thumb - 1/2 duty cycle, 30 minutes on and 30 minutes of f in each hour, let vibrator cool to ambient (room) temperature.
  - C) Mounting bolts & compression washers included with each model.
  - D) U1-75 & U1-500 drilled and tapped hole(s) to attach safety cable.

### DIMENSIONS

MODEL	Bolt Pattern						Bolt Size/Qty		Weight/Lbs.		
	A	B	C	D	E	F	G	H		I	J
U1-75	45/8"	33/8"	31/2"	21/4"	3"	11/4"	1/8"	31/4"	15/8"	1/4" x 3/4" /4	5 lb.
U1-500	71/2"	45/8"	63/4"	11/2"	51/2"		7/8"	37/8"	21/8"	3/8" x 11/4" /2	14 lb.
U1-1600	91/16"	59/16"	63/8"	61/4"	5"	33/4"	11/8"	41/4"	2"	3/8" x 11/2" /4	23 lb.

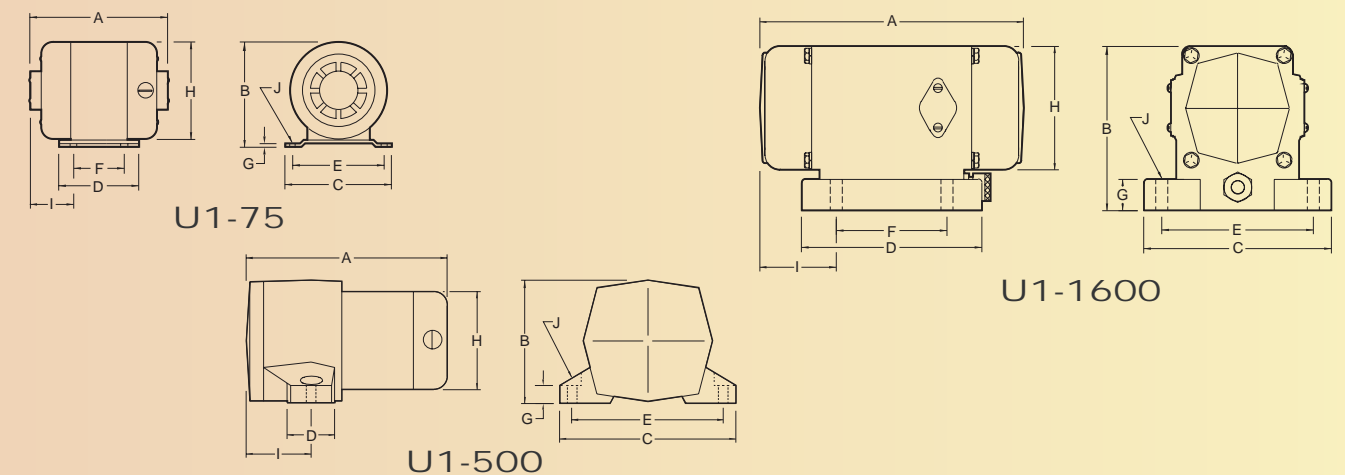

### ACCESSORIES

MODEL	A	B	C	D <sup>6</sup>	E	F
U1-75				194269	115v 230v 196751	220300
U1-500			220522	STD.	196751 196752	220300
U1-1600	223014	223015	220505	STD.	196754 196755	

6) Nema4 Enclosure

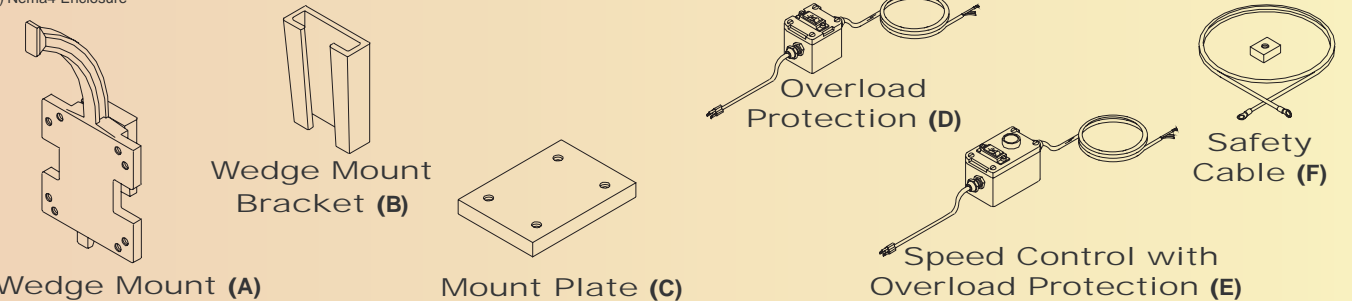

### WARRANTY

All Deca Vibrator products are covered by a one year limited warranty. Ask for details.